



The PER-FIL® Model MF-1HCW NET WEIGH SERVO Auger Filler is designed for precise filling of powder, granular, and paste products.

Precise, servo driven auger, for optimum control over fill accuracy. Separate DC-Variable speed agitator drive to control product consistency.

OFF-THE-SHELF PLC with touchscreen interface for simple adjustment of all filler parameters.

304 stainless steel product contact parts standard or 316 electro-polished stainless steel upgrade.

OFF-THE-SHELF Scale for fill-by-weight operation for optimum fill accuracy control.

Dust shroud to enclose container for dust-free filling.

Modular machine design adapts to semi or fully automated production lines using rigid or flexible containers of various shapes and configurations. Convenient integration with in-line or rotary index turret equipment.

Production rates from 2 – 10 fills per minute.

The Per-Fil MF-1W Features:

- **Touchscreen control with 30 product memory**
- **Stainless Steel Construction.**
- **Quick release hopper and auger removal**
- **Unique hopper mount to avoid misalignments**

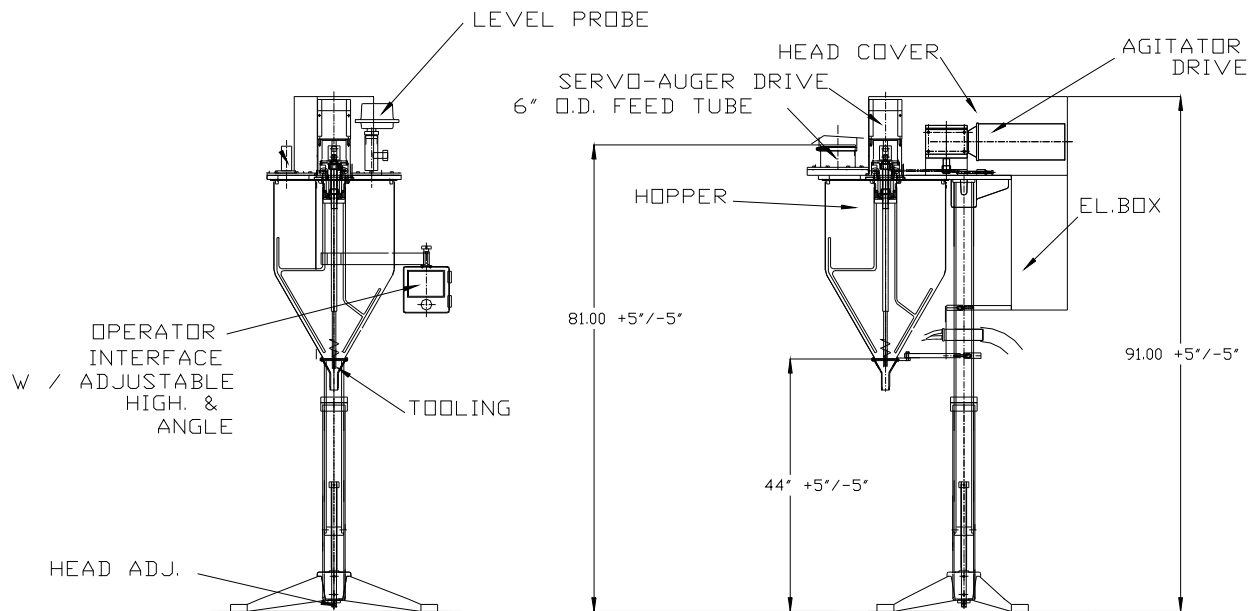

Specifications

Fill Range:	5 kg – 75 kg.
Production Rates:	2 - 10 fills per minute
Fill Accuracy:	± 0.5% to 3% of net weight
Auger Drive:	Servo; 2.0 HP, 3000RPM
Agitation Drive:	DC-Variable speed 0-90 RPM
Controls:	OFF-THE-SHELF PLC with Touchscreen display
Electrical:	220 volts/60 hertz/3 phase or other as specified by customer
Operation:	Semi-Automatic or Fully Automatic
Construction:	Heavy Duty; SST product contact parts

PER-FIL® Industries Inc.
407 Adams Street - P.O. Box 9 – Riverside, NJ 08075
(856)-461-5700 – Fax (856)-461-0741
E-mail: sales@per-fil.com - www.per-fil.com

**Per-Fil
Industries**
Precision Filling
Equipment