

The Per-Fil Model PF-26 is an automatic filling system; its modular design allows for high speed filling of difficult products and containers.



The Per-Fil Industries Model PF-26 can fill virtually any rigid container at speeds up to 80 cpm.

This rugged fill system features our ultra precise clutch brake fill head; heavy duty SST base with maintenance-friendly see through access doors; 12'-0" long conveyor with fill zone dust troughs.

Available options include: Jack screw head height adjustment; 6" stroke container lift for compression or bottom-up filling; vibrating wearstrip bridge; multiple conveyor designs to accommodate the specific needs of different styles of containers; volumetric or high resolution weigh cells for net or gross weight filling.

PF-26

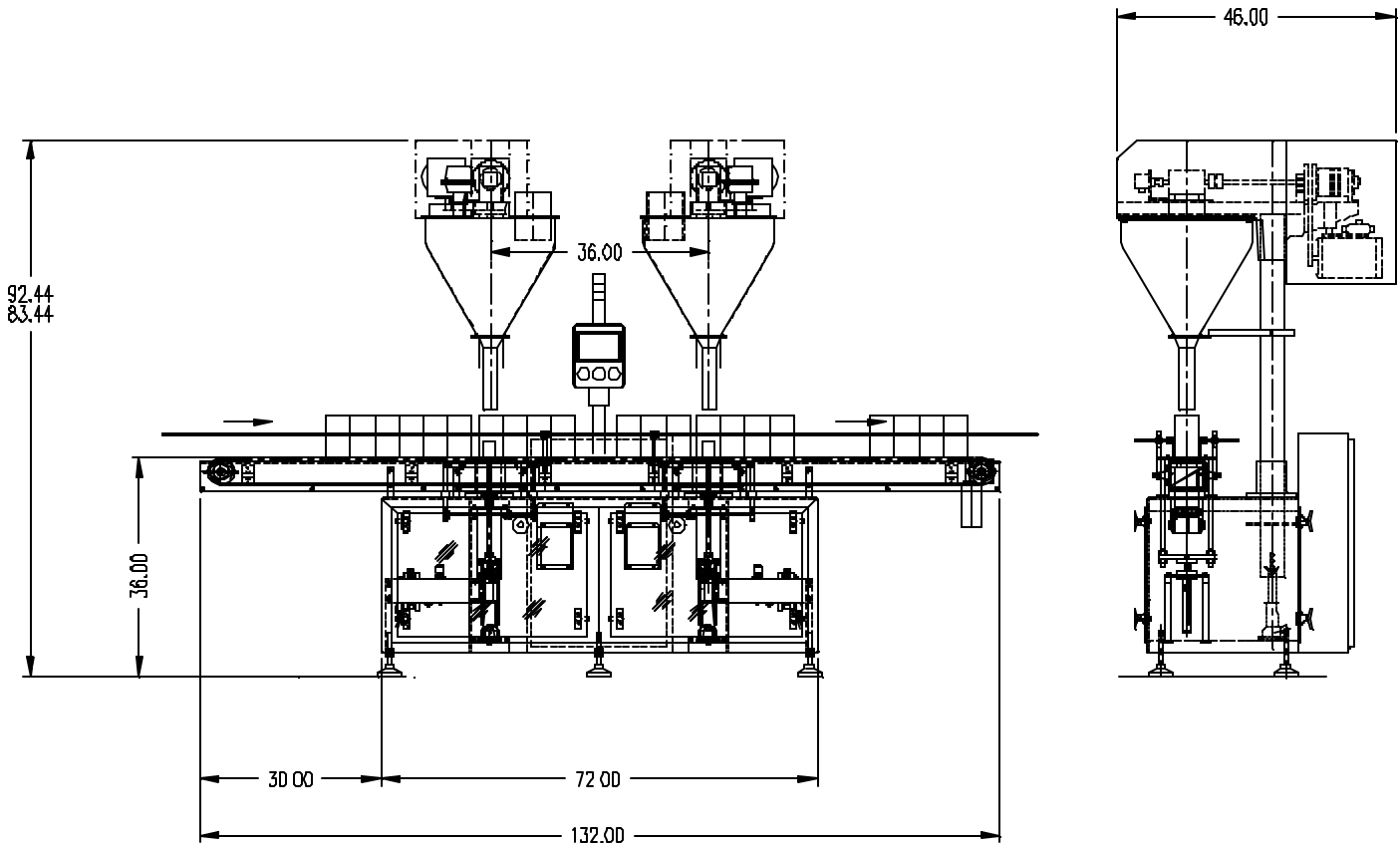

Products Filled:	Powders, Granules, Pastes, Liquids, frozen and Processed Food
Fill Speed:	20-80 Fills/minute
Containers Filled:	Bottles, Jars and Boxes
Fill Accuracy:	+/- 1 % or better
Fill Range:	0.5 grams to 10kg
Operation:	Automatic
Hopper Capacity:	2 to 5 cubic feet, depending on application
Construction:	All stainless steel product contact parts with NEMA 12 controls. Also available with NEMA 4X controls and sanitary construction.
Physical Size:	4' x 12' x 7.5'
Cleaning/Changeover Time:	40-60 minutes
Availability:	6-8 weeks
Budgetary Pricing:	\$35,000 to \$55,000*
Special Features:	Available with servo drive or clutch/brake. Turnkey systems available. CE Mark.

Per-Fil Industries Inc.
 407 Adams Street - P.O. Box 9 – Riverside, NJ 08075
 (856)-461-5700 – Fax (856)-461-0741
 E-mail: sales@per-fil.com - www.per-fil.com

