

**The Per-Fil Model PF-23 is an automatic filling system; its modular design allows for high speed filling of difficult products and containers.**



The Per-Fil Industries Model PF-23 can fill virtually any rigid container at speeds up to 40 cpm.

This rugged fill system features our ultra precise clutch brake fill head; heavy duty 3/16" SST base with maintenance-friendly see through access doors; 7'-0" long conveyor with fill zone dust trough.

*Available options include:* Jack screw head height adjustment; 6" stroke container lift for compression or bottom-up filling; vibrating wearstrip bridge; multiple conveyor designs to accommodate the specific needs of different styles of containers; volumetric or high resolution weigh cells for net or gross weight filling.

# PF-23

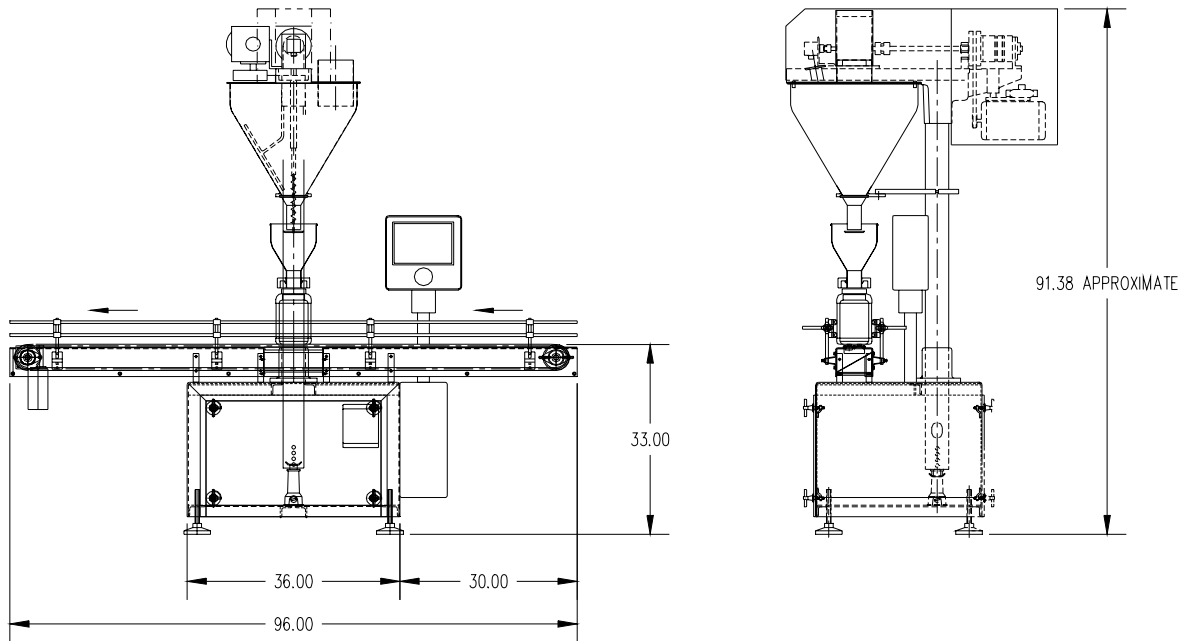

<b>Products Filled:</b>	Powders, Granules, Pastes, Liquids, frozen and Processed Food
<b>Fill Speed:</b>	10-40 Fills/minute
<b>Containers Filled:</b>	Bottles, Jars and Boxes
<b>Fill Accuracy:</b>	+/- 1 % or better
<b>Fill Range:</b>	0.5 grams to 10kg
<b>Operation:</b>	Automatic
<b>Hopper Capacity:</b>	1 to 5 cubic feet, depending on application
<b>Construction:</b>	All stainless steel product contact parts with NEMA 12 controls. Also available with NEMA 4X controls and sanitary construction.
<b>Physical Size:</b>	4' x 8' x 7.5'
<b>Cleaning/Changeover Time:</b>	30-45 minutes
<b>Availability:</b>	6-8 weeks
<b>Budgetary Pricing:</b>	\$27,000*
<b>Special Features:</b>	Available with one or more fill heads. Available with servo drive or clutch/brake. Turnkey systems available. CE Mark.



Per-Fil Industries Inc.  
 407 Adams Street - P.O. Box 9 – Riverside, NJ 08075  
 (856)-461-5700 – Fax (856)-461-0741  
 E-mail: [sales@per-fil.com](mailto:sales@per-fil.com) - [www.per-fil.com](http://www.per-fil.com)

