



The Per-Fil Model MF-1 SERVO auger filler is designed for precise filling of powder, granular, liquid and paste products.

Precise, servo driven auger, for optimum control over fill accuracy. Separate DC-Variable speed agitator drive to control product consistency.

OFF-THE-SHELF PLC with touchscreen interface for simple adjustment of all filler parameters. Can be integrated with scale for net weight fill operation or with checkweigher to feedback and adjust the auger dispense counts.

304 stainless steel product contact parts standard or 316 electro-polished stainless steel upgrade.

Modular machine design adapts to semi or fully automated production lines using rigid or flexible containers of various shapes and configurations. Convenient integration with in-line or rotary index turret equipment.

Production rates from 10 – 120 fills per minute.

The Per-Fil MF-1 Features:

- Touchscreen control with 99 product memory
- Stainless Steel Construction.
- Quick release hopper and auger removal
- Unique hopper mount to avoid misalignments

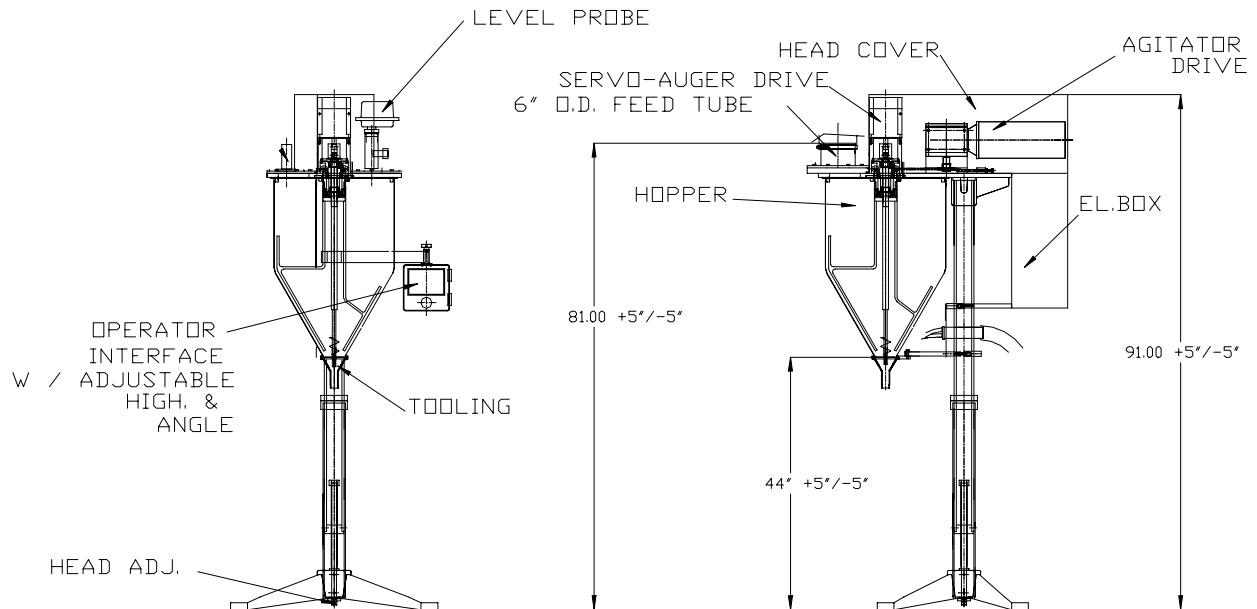

Specifications

Fill Range:	0.5 gram – 100 lbs.
Production Rates:	10-120 fills per minute
Fill Accuracy:	±1% to 3% of net weight
Auger Drive:	Servo; 2.0 HP, 3000RPM
Agitation Drive:	DC-Variable speed 0-90 RPM
Controls:	OFF-THE-SHELF PLC with Touchscreen display
Electrical:	220/60/3
Operation:	Semi-Automatic or Fully Automatic
Construction:	Heavy Duty; SST product contact parts

Per-Fil Industries Inc.
407 Adams Street - P.O. Box 9 – Riverside, NJ 08075
(856)-461-5700 – Fax (856)-461-0741
E-mail: sales@per-fil.com - www.per-fil.com

